

60HZ TECHNICAL DATA SHEET

CATALOG No: **BC6N020V4C**

ISSUED: 14-Mar-24

GENERAL INFORMATION

HP	KW	Pole	RPM	Frame	Voltage	Hz	Phase	IP Rating
20	15.00	6	1200	286TC	230/460 V	60	3	IP55

Enclosure	Ins. Class	Service Factor	Time Rating	NEMA Design	Rated Amb.	Rated Altitude
TEFC	F	1.25	Continuous	B	-15 to 40 C°	<3300 ft

TYPICAL PERFORMANCE

Efficiency (%)			Power Factor (%)		
Full Load	3/4 Load	1/2 Load	Full Load	3/4 Load	1/2 Load
91.7	92.1	91.9	0.84	0.79	0.70

LRT%	BDT %	Full Load Amps	Locked Rotor Amps	Full Load RPM
		460 V	460 V	
140	260	24.40	139.57	1180

NEMA KVA Code	Bearing Size		Oil Seal		Sound Level
	Drive End	Non-Drive End	Drive End	Non-Drive End	dB(A)
F	63102Z	63082Z	-	-	-

*Weights shown are estimated and based on standard foot mounted motor designs

VFD DUTY INFORMATION

	Variable Torque	Constant Torque	Rating
-	6 - 60 Hz	12 - 60 Hz	CSA Approved Class I; Div 2; Groups A, B, C, & D, T3 With VFD
-	-	-	

Click Link Below For Drawing

[Drawing Not Available](#)

Click Link Below For Connection Diagram

<http://www.brookcrompton.com/Connections/Connection%20Diagram%2012%20Lead%20X4%20NEMA.pdf>

Notes:

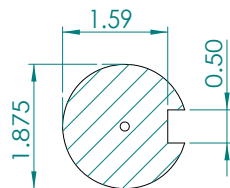
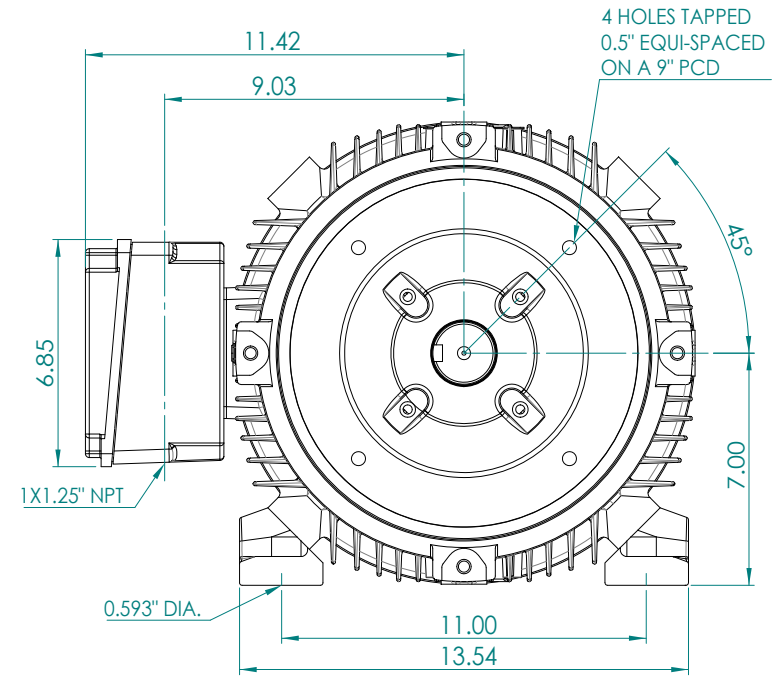
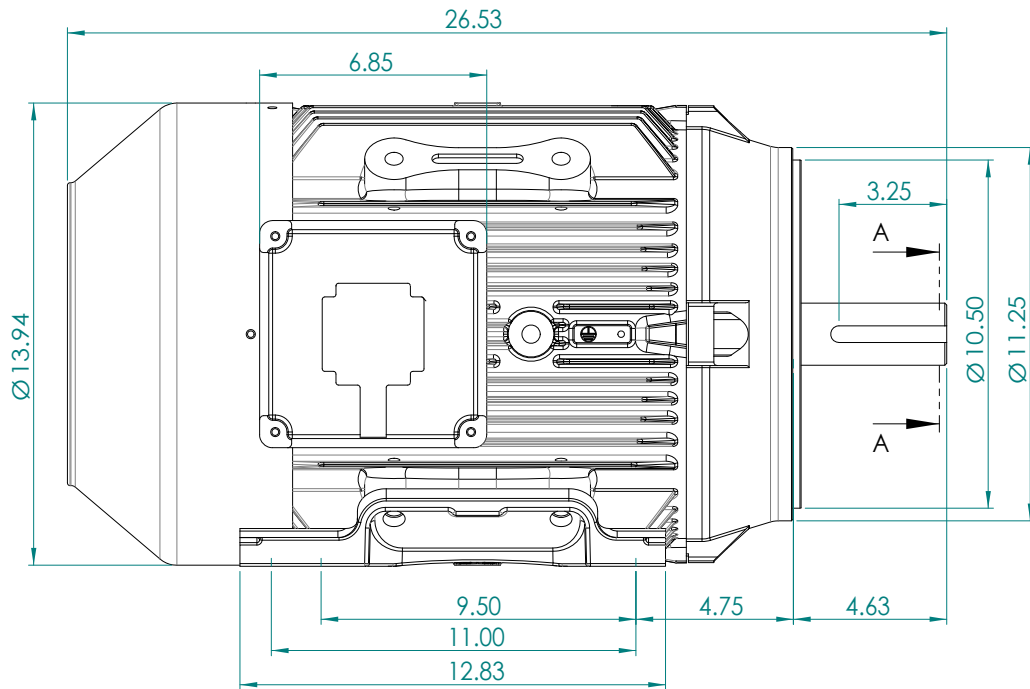

SECTION A-A
SCALE 1 : 2

**BROOK
CROMPTON**

WPN-DF284/6TC-V

A3

SHEET

www.brookcrompton.com