

DART

CONTROLS

Instruction Manual

EZ VFD®

*Universal AC Input 110 – 240VAC
230VAC / 3Φ Output 800W*



5000 W. 106th Street
Zionsville, Indiana 46077

Phone (317) 873-5211
Fax (317) 873-1105
www.dartcontrols.com

Table of Contents

Introduction.....	2
General Features	2
Models & Options	3
Specifications	3
EZ VFD® Models.....	3
EZ VFD® Electrical.....	3
EZ VFD® Mechanical.....	3
EZ VFD® Environmental.....	3
Mechanical Installation.....	4
Mounting Dimensions	4
Installation & Diagrams.....	5
Hook-Up Diagram	5
Enclosed Hook-Up Diagram	5
P9 Terminal Block Hook-Up Diagram.....	6
P9 Terminal Block Descriptions.....	6
CUSTOMER INSTALLATION, WIRING, & FUSING REQUIREMENTS	7
AC Line Fusing	7
Factory Default Trimpot and Jumper Settings.....	7
Pot Board.....	7
'MAX' Trimpot.....	8
'MIN' Trimpot.....	8
'ACCEL' Trimpot.....	8
'DECEL' Trimpot.....	9
'CL' Trimpot	9
'BOOST' Trimpot	9
'BRAKE' Trimpot.....	10
Basic Operating Information	10
-R Option - Run Relay Activation.....	10
Troubleshooting.....	10
Technical Support Options	10
What's Special About www.dartcontrols.com ?	10

WARRANTY

Dart Controls, Inc. (DCI) warrants its products to be free from defects in material and workmanship. The exclusive remedy for this warranty is DCI factory replacement of any part or parts of such product which shall within 12 months after delivery to the purchaser be returned to DCI factory with all transportation charges prepaid and which DCI determines to its satisfaction to be defective. This warranty shall not extend to defects in assembly by other than DCI or to any article which has been repaired or altered by other than DCI or to any article which DCI determines has been subjected to improper use. DCI assumes no responsibility for the design characteristics of any unit or its operation in any circuit or assembly. This warranty is in lieu of all other warranties, express or implied; all other liabilities or obligations on the part of DCI, including consequential damages, are hereby expressly excluded.

NOTE: Carefully check the control for shipping damage. Report any damage to the carrier immediately. Do not attempt to operate the drive if visible damage is evident to either the circuit or to the electronic components.

All information contained in this manual is intended to be correct, however information and data in this manual are subject to change without notice. DCI makes no warranty of any kind with regard to this information or data. Further, DCI is not responsible for any omissions or errors or consequential damage caused by the user of the product. DCI reserves the right to make manufacturing changes which may not be included in this manual.

WARNING

Improper installation or operation of this control may cause injury to personnel or control failure. The control must be installed in accordance with local, state, and national safety codes. Make certain that the power supply is disconnected before attempting to service or remove any components!!! If the power disconnect point is out of sight, lock it in disconnected position and tag to prevent unexpected application of power. Only a qualified electrician or service personnel should perform any electrical troubleshooting or maintenance. At no time should circuit continuity be checked by shorting terminals with a screwdriver or other metal device.

AVERTISSEMENT

Toute installation ou exploitation irrégulière de cette commande peut causer des blessures au personnel ou une panne à la commande. La commande doit être installée en respectant les codes de sécurité locaux, fédéraux et nationaux. Assurez-vous que l'alimentation est coupée avant de maintenir ou d'enlever des composants !!! Si le point de coupure de courant n'est pas visible, bloquez-le à la position de déconnexion et étiquetez-le pour éviter tout mise sous tension imprévue. Toute localisation de panne électrique ou maintenance devrait être effectuée par un électricien qualifié. La continuité du circuit ne devrait en aucun cas être vérifiée en court-circuitant les bornes avec un tournevis ou tout autre objet métallique.

Introduction

The EZ VFD® Series is a volts/Hz variable frequency drive for 3-phase, 230VAC inverter duty AC motors. The EZ VFD® comes in two styles – open chassis for control panel installation, and a stand-alone NEMA 4X enclosed model. The EZ VFD® is suited for both constant torque (ex: conveyor, auger) and variable torque (ex: fans, blowers and centrifugal pumps). Care must be taken with variable torque applications not to exceed the load current ratings of the EZ VFD®.

The EZ VFD® name indicates the philosophy of the product's design – it is intended to be the simplest to use Variable Frequency Drive on the market. The factory presets of all adjustments (trimpots) will work well in most applications without change – if changes are needed they are easy to accomplish using the instructions that follow.

Though basic in design, the EZ VFD® offers an optional ModbusRTU Serial Interface to support networked solutions, and allow remote access / cloud based / advanced smart phone control and data acquisition via Modbus connection to a supervisory control / plc / HMI.

General Features

- Digital Signal Processor provides digital accuracy, repeatability, and stability in industrial environments
- Single board design is more rugged and vibration tolerant than stacked / multi-board designs
- Suitable for constant and variable torque applications where the input load does not exceed 800 Watts continuous (Supply Voltage x Supply Current)
- Universal power supply accepts supply voltages of 110-240VAC @ 50-60Hz
- Transient voltage protection protects device in harsh industrial environments
- Open frame or NEMA 4X enclosed housing
- Euro style terminal strip for control inputs and outputs; 1/4" male spade terminals for supply voltage and motor connections
- Wide operating temperature -10°C to +40°C (14°F to 104°F)
- Selectable fwd/rev input terminal allows you to choose the motor direction.
- Run/enable terminal provides a means to start and stop the drive without a full power down. It also allows for resetting the drive after a fault.
- Brake terminal allows for a controlled stop with adjustable DC injection braking at stop to hold motor in position.
- Easily adjustable control function such as min, max, acc, dec, CL, brake and boost, that can be adjusted on the fly.
- Easy full range speed adjustment via a speed pot.

Models & Options

Models	Description
VF-100C	Open chassis, universal AC input, 230VAC 3 Phase Out, Potentiometer / 0-5VDC follower speed adjustment; MIN, MAX, BOOST, ACCELERATION, DECELERATION, CURRENT LIMIT, BRAKING trimpot adjustments
VF-100E	NEMA 4X enclosed, universal AC input, 230VAC 3 Phase Out, Potentiometer / 0-5VDC follower speed adjustment; MIN, MAX, BOOST, ACCELERATION, DECELERATION, CURRENT LIMIT, BRAKING trimpot adjustments
Options	Description
-MBRTU	Optional field installable ModBusRTU Serial Interface – see details in separate manual
-R	Optional Form C Run Relay output – Factory installed only
-TP	Optional removable Trimpot Board – Factory supplied only

Specifications

EZ VFD® MODELS

MODELS	INPUT VOLTAGE	INPUT FREQ	INPUT PHASES	OUTPUT VAC	OUTPUT PHASES	OUTPUT FREQ	OUTPUT I/PH
VF-100C	115	50/60	1 Ph	230	3	0 – 60/120*	2.4 Amps
	230	50/60	1 Ph	230	3	0 – 60/120*	3.2 Amps
VF-100E	115	50/60	1 Ph	230	3	0 – 60/120*	2.4 Amps
	230	50/60	1 Ph	230	3	0 – 60/120*	3.2 Amps

*NOTE: Output Freq greater than 60Hz must de-rated load current by up to 20%. See de-rate chart under Max Trimpot setting.

EZ VFD® Electrical

Line Input Voltage (Min – Max)	Any Voltage from 110-240 VAC
Line Input Frequency	Any Freq. from 48-62 Hertz
Speed Voltage Signal Input (+5VDC from terminal block)	0-5 VDC
Motor Inverter Voltage Output	~230VAC effective, ~390Vpk PWM @ 8KHz
Boost Slope	3V / Hz
Onboard Power Supply (Externally Accessible)	5V @ 25mA

EZ VFD® Mechanical

Housing Type	Open Chassis or NEMA 4X
Connector Style	¼" male spade terminals for supply voltage and motor
Terminal Block Torque Setting	1.95 in lb (.22Nm) to 2.21 in lb (.25Nm)
Housing Material	6063-T6 Aluminum / Sabic NORYL TYPE N190
Length	7.150", 181.61mm
Width	5.53", 140.46mm
Height	5.942", 150.93mm
Weight	3.177 lb, 50.832 oz, 1441.06g

EZ VFD® Environmental

Operating Temperature Range	-10C to 40C (14F to 104F)
Operating Humidity Range	95%, non-condensing
Operating Altitude	2000M

Mechanical Installation

Mounting Dimensions

Enclosed Dimensions

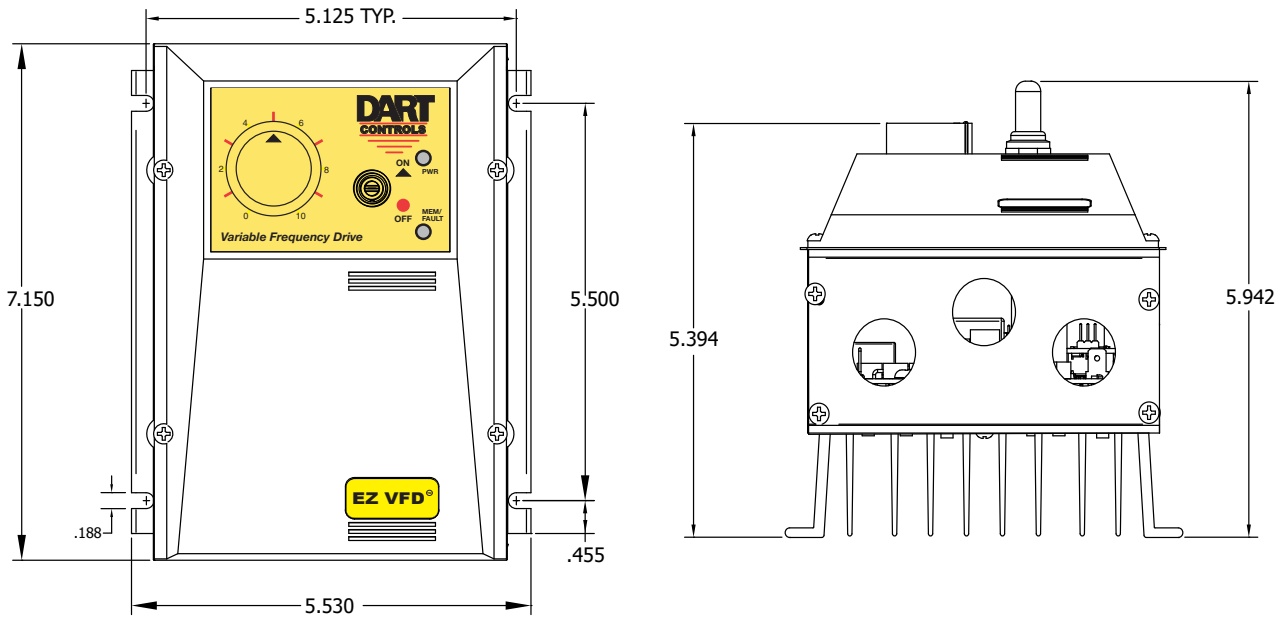

Chassis Dimensions

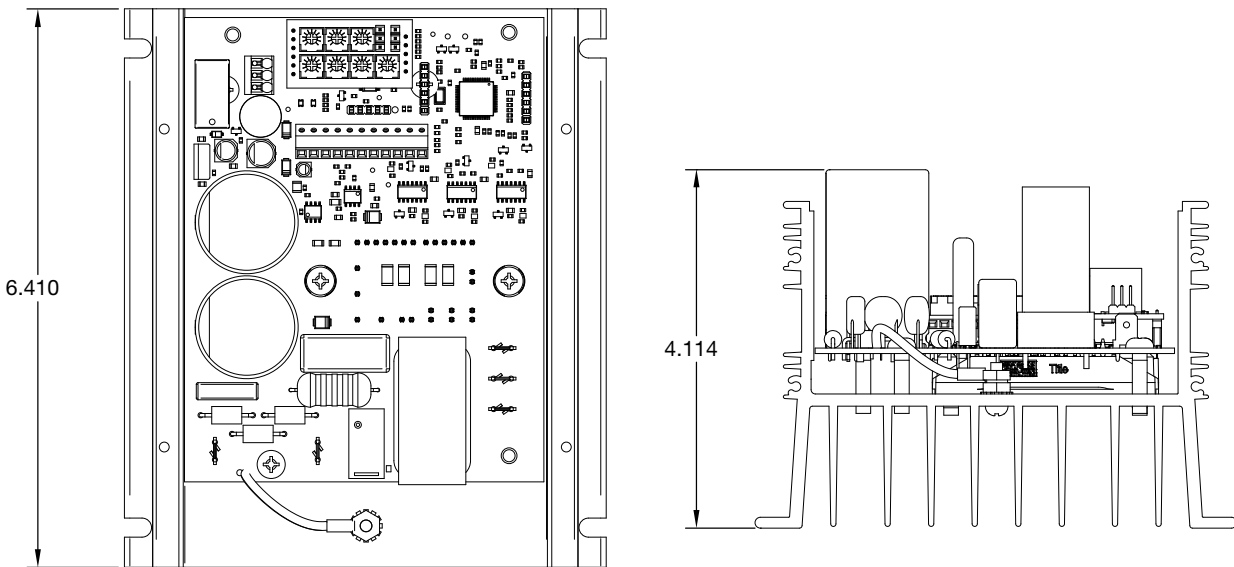

Note: Drive must be mounted such that the fins are in a vertical orientation. When mounted vertically, there must be adequate spacing between the fins and any other object to allow for air flow through the fins.

Remarque : le variateur doit être monté de manière à ce que les ailettes soient dans une orientation verticale. Lorsqu'il est monté verticalement, il doit être un espacement adéquat entre les ailettes et tout autre objet pour permettre la circulation de l'air à travers les ailettes.

CAUTION:

DO NOT MOUNT WHERE AMBIENT TEMPERATURE IS OUTSIDE THE RANGE OF -10° C (14° F) TO 40° C (104° F)

ATTENTION:

NE MONTEZ PAS LA COMMANDE À UN EMPLACEMENT OÙ LA TEMPÉRATURE AMBIANTE SE TROUVE EN DEHORS DE LA PLAGE ALLANT DE -10°C (15°F) À 40°C (104°F).

Installation & Diagrams

Hookup Diagram

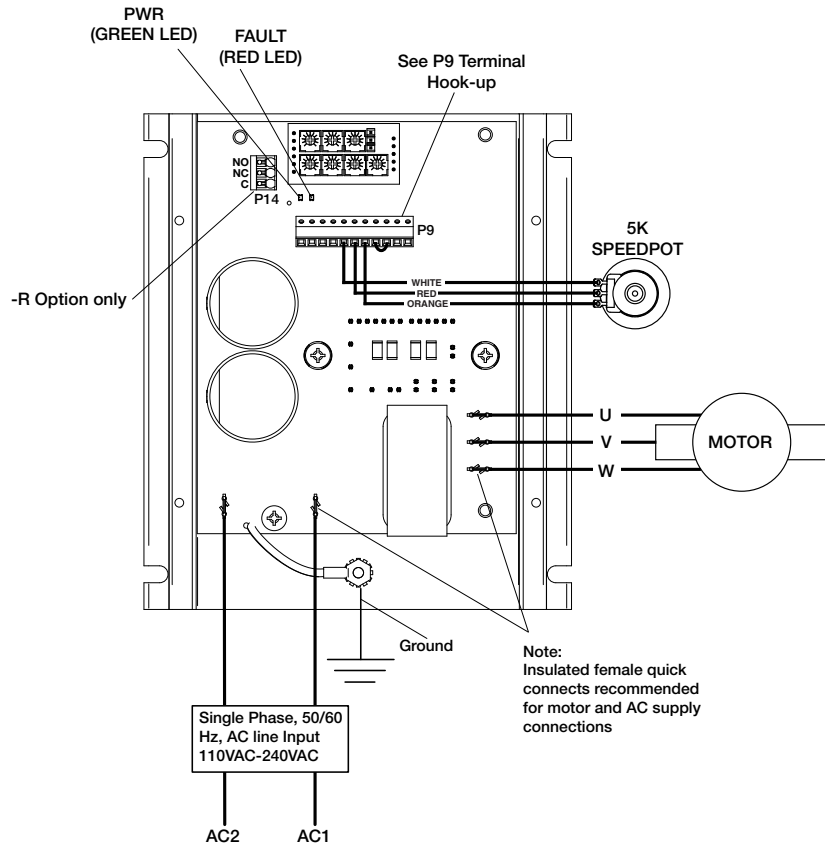

Enclosed Hook-Up Diagram

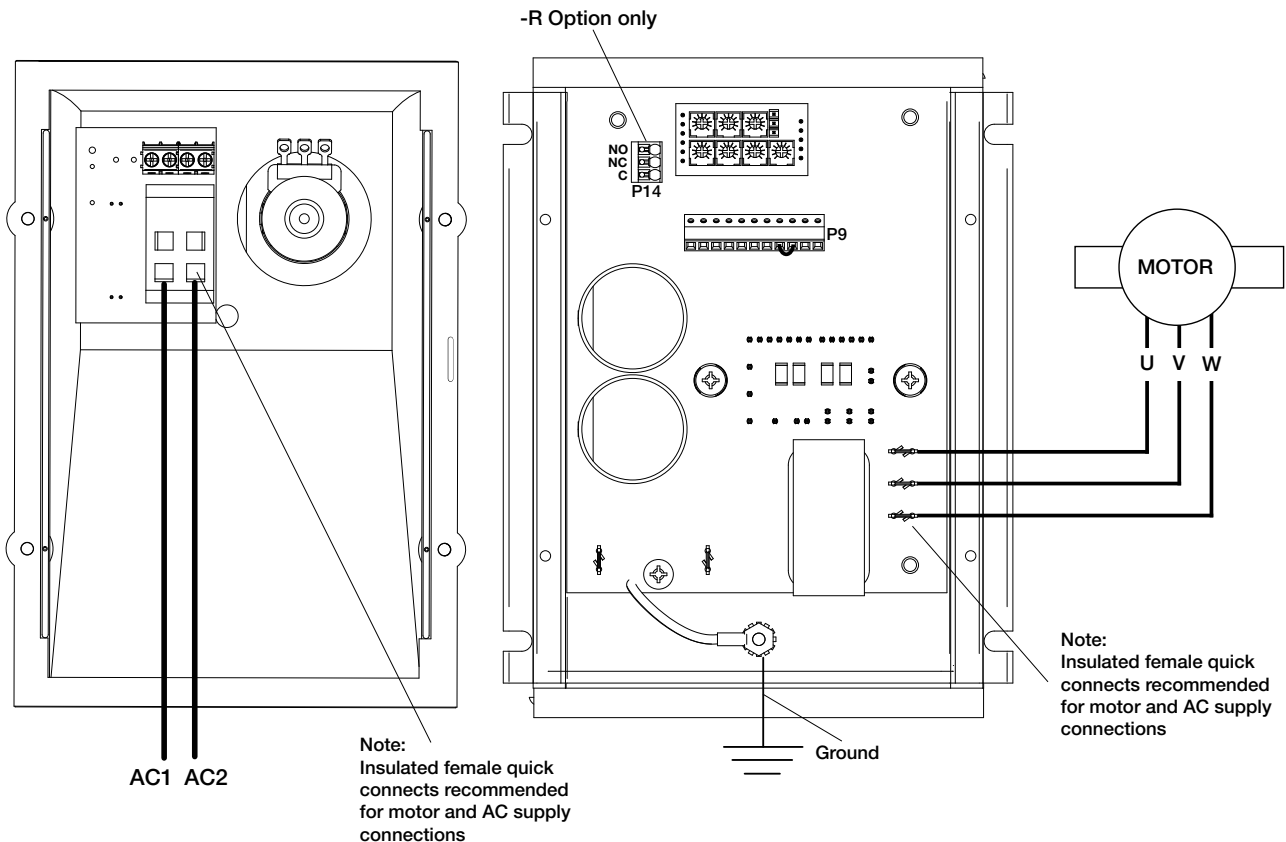

P9 Terminal Block Hook-Up Diagram

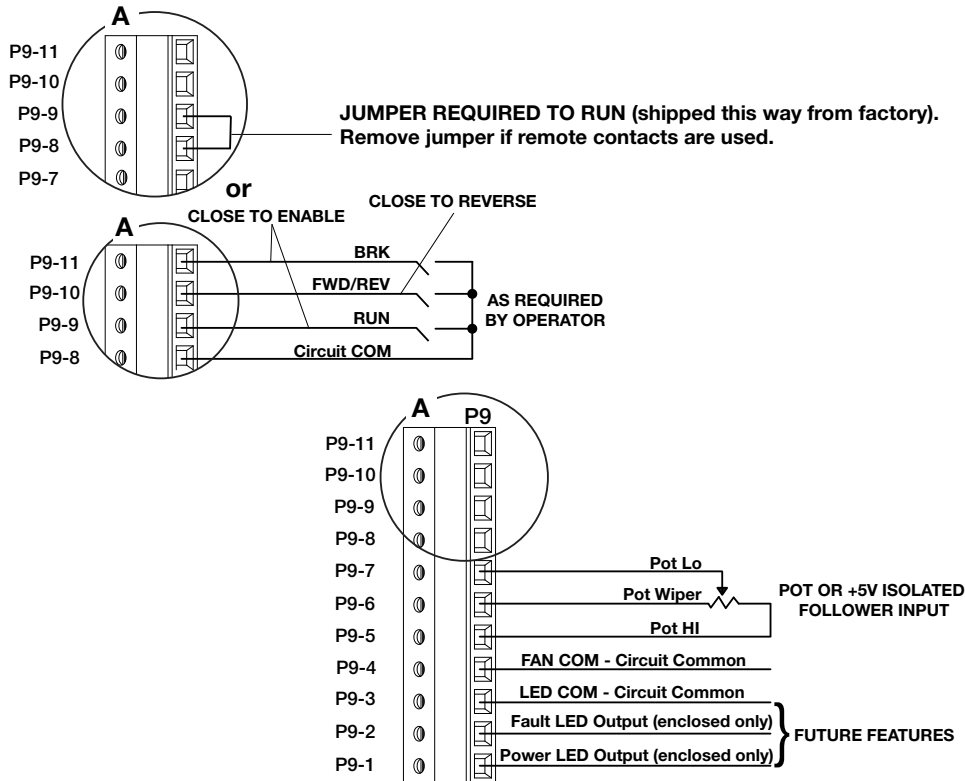

WARNING:

The signal inputs of P9 must be isolated from the AC line. Any Earth grounding of the signal wiring will damage the drive and void the warranty. To avoid electrical shock or damage to the drive due to accidental grounding, power must always be turned off while connecting to these inputs.

ATTENTION:

Les entrées de signal de P9 doivent être isolées de la ligne CA. Toute mise à la terre du câblage du signal endommagera le variateur et annulera la garantie. Pour éviter les chocs électriques ou les dommages au variateur dus à une mise à la terre accidentelle, l'alimentation doit toujours être coupée lors de la connexion à ces entrées.

P9 Terminal Block Descriptions

- P9-1 Power LED Output (enclosed only).
- P9-2 Fault LED Output (enclosed only).
- P9-3 LED COM - Circuit Common used for LED return on enclosed models.
- P9-4 FAN COM - Circuit Common.
- P9-5 HI - +5V pot Hi connection for 5K ohm speed pot. This input can also accept a 0-5Vdc isolated signal input.
- P9-6 W - Wiper connection for 5K ohm speed pot. The wiper input can also be used to reset a CL or Fault shutdown by bringing the wiper input from above 50% down to zero.
- P9-7 LO - Circuit common connection for pot LO of the 5K ohm speed pot or common return for isolated 0-5Vdc signals..
- P9-8 COM - Circuit common (Logic 'Low') connection for Run, Brake and Reverse inputs.
- P9-9 RUN - This input floats 'Logic High' - must be connected via switch or jumper to P9-8 (Common) for drive to Run. This input can also be used to clear a CL or Fault shutdown by opening the Run terminal and then closing it to com again.
- P9-10 FWD/REV - To change motor direction, this input must be connected to P9-8 (Common).
- P9-11 BRK - When connected to P9-8 (Common) the motor will decel to a stop and then provide DC injection braking at the rate set by the BRK trimpot.

NOTE - A full ccw trim pot setting disables braking.

CUSTOMER INSTALLATION, WIRING, & FUSING REQUIREMENTS

- Do not mount EZ VFD® where ambient temperature is outside the range of -10 to 40°C (14 to 104°F).
- Installations in unventilated enclosures must be 1.5 times the controller dimensions or more, and the air temperature inside the enclosure and around the controller must remain between 10 to 40°C (14 to 104°F).
- **Keep signal wires separate** from the motor and AC lines when routed in conduit or wire trays.
- These drives do not provide motor over-temperature sensing or shutdown. The need for additional motor and motor over-temperature protection shall be determined based on conditions in the end installation in accordance with the NEC.
- Size all wires that carry motor or line currents as specified by applicable national, state, and/or local codes. All other wires may be 18AWG or smaller as permitted by code.

Type	Customer Wiring Temp Rating
Customer Terminal Wiring	300V, 75°C(167°F) minimum

- "Integral solid state short circuit protection does not provide branch circuit protection. Branch circuit protection must be provided in accordance with the National Electrical Code and any additional local codes," or the equivalent.
- **Fusing** - The motor and control are protected against overloads by the current limit circuit, however this drive does not contain AC line fuses. Most electrical codes require that each hot AC Line conductor contain circuit protection. Install a fuse (See fusing chart below) or a circuit breaker in series with each hot AC Line. Do not fuse any of the motor leads. For recommended fuse size, see the chart below.
- The control and motor must be wired in accordance with the National Electrical Code requirements and other local codes that may apply.

FUSING ADDED BY CUSTOMER (Bussman ABC or Littelfuse 326 Series fuses)

230 VAC 3 ϕ Motor Hp	115 VAC INPUT	230 VAC INPUT
1/4	5 AMP	5 AMP
1/2	10 AMP	5 AMP
1.0	-	10 AMP

Factory Default Trimpot and Jumper Settings

Pot Board

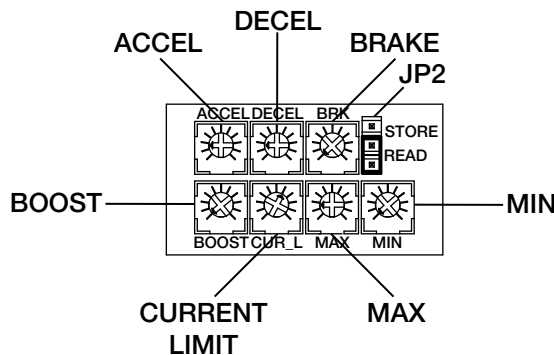

Initial Trimpot Settings

The trimpots are factory set for a 0-60 Hz 1Hp inverter duty motor. The initial settings are as follows:

MIN, BOOST, BRAKE Pots - Full CCW

CURRENT LIMIT Pot - 2/3 CW - 7 on the trimpot face (approx 3.4 A AC RMS)

DECEL, ACCEL, MAX - 1/4 CW - 2 to 3 on pot face

JP2 Jumper

JP2 – When set to READ the trimpots can be actively adjusted and tuned for the users specific application. Every trimpot can be adjusted and tested while running a motor. Once the drive has been tuned to the desired setting, those settings can be stored to memory and locked by moving the jumper to the STORE position.

'MAX' Trimpot

The MAX trimpot range is 48 - 120Hz. The MAX trimpot comes factory set to 60Hz. To decrease the MAX speed setting, turn the trimpot CCW to the desired speed. To increase the MAX speed setting, turn the trimpot CW to the desired speed. Refer to the MAX trimpot diagram for range settings.

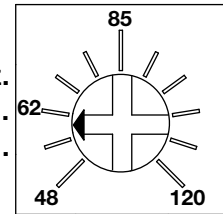

MAX Hz

NOTE: Speed settings above 60Hz will require the control RMS output current to be derated by up to 20% at 120Hz. Refer to de-rate graph below.

Caution: Operating a motor above its rated speed may result in some motors running hotter than normal. When operating a motor beyond its normal speed range the motor manufacturer should be consulted to determine if de-rating or additional cooling methods may be required.

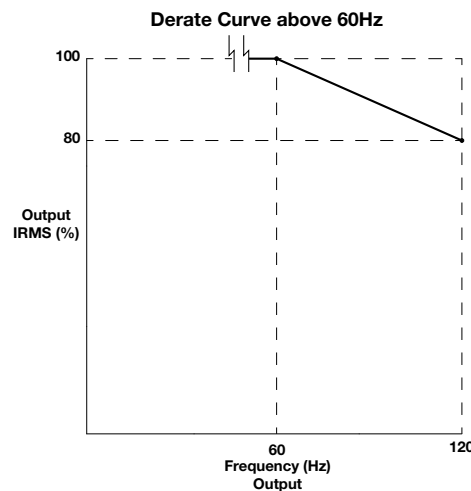

'MIN' Trimpot

The MIN trimpot range is 5-30Hz. The min pot is factory set at full CCW which is 0Hz. To increase the min set point, set the master speedpot to 0 on the dial and then adjust the MIN trimpot CW to the desired minimum speed when the master speedpot is set to zero.

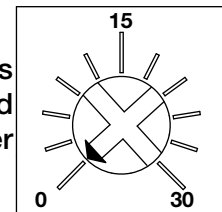

MIN Hz

'ACCEL' Trimpot

The adjustable range of ACCEL is a linear .5 to 30 second ramp from 0 - 60Hz. The ACCEL pot is factory set to approx 2 sec from 0-60Hz. A CCW adjustment will reduce the ramp time and a CW adjustment will increase the ramp time. Caution should be given to ACCEL ramp times below 2 sec as this may result in an over current shutdown.

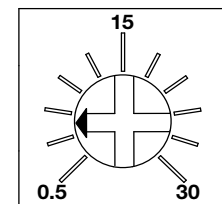

Rate 0 - 60 Hz
Time
in sec.

Note: Higher MAX setting will result in longer ramp times. A MAX setting of 120Hz will extend ACCEL range from 1 - 60 sec.

'DECEL' Trimpot

The adjustable range of DECEL is a linear .5 to 30 second ramp from 60 - 0Hz. The DECEL pot is factory set to approx 2 sec from 60-0Hz. A CCW adjustment will reduce the ramp time and a CW adjustment will increase the ramp time. Caution should be given to DECEL ramp times below 2 sec as this may result in an over current shutdowns.

Note: Higher MAX setting will result in longer ramp times. A MAX setting of 120Hz will extend the DECEL range from 60-1 sec.

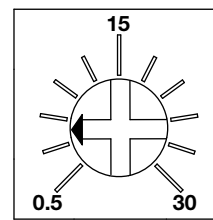

Rate 60 - 0 Hz
Time
in sec.

'CL' Trimpot

Overview

The control current limit operates as an over current shutdown that will trip the drive off in a safe manor any time the CL set point is exceeded. When the CL set point has been tripped the Red Fault LED (located on circuit board of a chassis model or on the cover of an enclosed model) will illuminate steady when the drive is in a Current Limit state. The initial CL trips can easily be reset via the Run input or the Master Speedpot however repeated CL trips will result in a CL Shutdown. (See “Resetting CL Trips and Shutdowns” below) The Current Limit (CL) trimpot is Factory set to 4.8 amps RMS. A CW rotation of the CL trimpot will increase the CL set point. A CCW rotation of the trimpot will decrease the CL setpoint. CL should typically be set to 150% of the rated motor phase current.

Setting CL

To adjust current limit for other motors, place a RMS current meter in series with one of the motor phases. Using the master control speedpot, set the control output to between 50 and 70% of rated motor output speed. Load the motor to 150% of its rated motor phase current and gradually decrease the CL trimpot setting until the red Fault LED turns on and the output shuts off. Cease any further trimpot change and release the motor load. To verify the correct setting, follow the CL reset process that is outlined below and then slowly increase the motor load while monitoring the RMS current meter until you reach the CL trip point again to verify the correct setting.

Resetting CL Trips and Shutdowns

A current limit trip can be reset via the Master Speedpot or by the Run input. Using either method, both the Green Pwr LED and the Red Fault LED will cycle off and then the Green Pwr LED will cycle back on while the Red Fault LED will remain off. This indicates that the CL trip has been reset and the drive will return to a ready state.

- 1) Run Input - To reset the CL trip, open the 'Run' input (P9-9 to P9-8) until the Red and Green LED's turns off and the Green LED turns back on.
- 2) Master Speedpot – The speedpot must be set above 50% and then turned to full CCW until the Red and Green LED's turns off and the Green LED turns back on.
- 3) CL Shutdown - If the CL has been tripped more that 3 times and the Red Fault LED fails to reset via method 1 or 2 then the control is in CL shutdown.

To reset the drive from a CL shutdown it will be necessary to cycle power to the drive

Note: Repeated CL Trips and Shutdowns are an indication of motor or system problems that should be evaluated further by a qualified systems technician.

'BOOST' Trimpot

The BOOST trimpot allows the the motor to overcome sluggish response at low speed starts or high' startup loads by boosting the output. To increase the boost setting rotate the BOOST trimpot CW. To decrease the boost setting rotate the BOOST trimpot CCW.

To determine if boost is required for your application, use the following setup method. With a normal motor load applied, slowly turn the MIN trimpot CW until you reach 30% rotation. If your motor has started up you will likely not need to adjust the BOOST trimpot. However if your motor hasn't started then slowly increase the BOOST trimpot until your motor starts to turn. Return the MIN setting to 0 (full CCW) and repeat the test to make sure the motor starts at low speeds.

Note: Running a motor continuously at low speeds with Boost turned up may cause some motors to over heat.

'BRAKE' Trimpot

Brake is a DC Injection Brake function when the motor speed is 0 Hz. This function can be used to hold a motor position in between speed commands. To activate Brake a contact must be closed from the BRAKE terminal on P9-11 to circuit Common on P9-8. A CW trimpot rotation will increase the level of DC injection braking. A CCW trimpot rotation will lower the level of braking. If Brake is activated while the motor is running then the motor will reduce to 0 speed at the rate of the DECEL trimpot setting. When the motor has stopped, the DC Injection Braking will be applied at a level determined by the trimpot setting.

Note: When the BRAKE trimpot is at full CCW the Brake function is fully disabled even if the BRAKE to COM contact has been closed.

CAUTION: Although the brake function can be limited by your CL setting, using Brake even at lower levels to hold a motor at 0 speed for extended periods of time can cause excessive heating of the motor.

Basic Operating Information

-R Option - Run Relay Activation:

The Run Relay is a SPDT user output relay that is normally activated if a run command is given. The output for both NC and NO can switch up to 1A loads at 30Vdc or 120Vac max.

Note: The relay output is active per the activation chart below regardless of the master potentiometer setting.

Run Input	Current Limit	IGBT Temperature exceeded shutdown value	EEPROM Corruption	Relay state
Active	Not exceeded	Not Exceeded	Not detected	ON
Inactive	Not exceeded	Not Exceeded	Not detected	OFF
Active	Exceeded	Not exceeded	Not detected	OFF
Active	Not exceeded	Exceeded	Not detected	OFF
Active	Not exceeded	Not exceeded	Detected	OFF

Troubleshooting

Technical Support Options

- Visit the Dart Controls Web Site at: www.dartcontrols.com
- Email technical support at: sales@dartcontrols.com
- Telephone technical support at 317-873-5211

What's Special About www.dartcontrols.com?

- Changes to printed material and product offerings first appear online
- Product manuals and other literature are easily accessible
- All information can be easily displayed or printed as needed

REPAIR PROCEDURE

In the event that a Product manufactured by Dart Controls Incorporated (DCI) is in need of repair service, it should be shipped, freight paid, to: Dart Controls, Inc., 5000 W. 106th Street, Zionsville, IN. 46077, ATTN: Repair Department. Please include Name, Shipping Address (no P.O. Box), Phone Number and if possible, e-mail address.

Those orders received from anyone without an existing account with DCI must specify if they will be paying COD or Credit Card (Master Card/Visa/American Express). This information is required before work will begin. If you have an account with Dart your order will be processed according to the terms listed on your account. Products with Serial Number date codes over 5 years old will automatically be deemed Beyond Economical Repair (BER). A new, equivalent device will be offered at a substantial discount.

Completed repairs are returned with a Repair Report that states the problem with the control and the possible cause. Repair orders are returned via UPS Ground unless other arrangements are made. If you have further questions regarding repair procedures, contact Dart Controls, Inc. at 317-873-5211.

YOUR MOTOR SPEED CONTROL SOLUTION PROVIDER

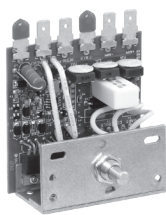

OEM Chassis SCR Drives
Dual Input voltage, adjustable HP range, isolated signal follower and reversing options

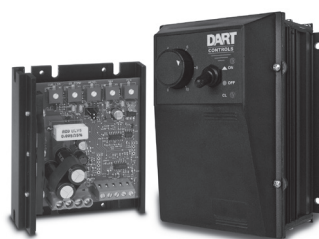
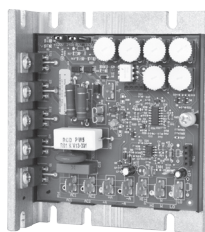

Low Voltage/Battery PWM Drives
Chassis and NEMA 4X versions, speed pot and signal follower operation



Digital SCR Drives
Closed loop accuracy, 4-20mA and serial communications, integral programmable display



Brushless DC Drives
Closed loop accuracy, line and low voltage versions through 1 HP



Digital Accessory & Resale Items

Motors to 700 HP, VFD's to 200 HP, NEMA rated encoder, digital programmable potentiometers and tachometers

Dart Controls, Inc. is a designer, manufacturer, and marketer of analog and digital electronic variable speed drives, controls, and accessories for AC, DC, and DC brushless motor applications.

Shown above is just a sampling of the expanded line of Dart controls that feature the latest in electronic technology and engineering. Products are manufactured in the U.S.A. at our Zionsville (Indianapolis, Indiana)

production and headquarters facility - with over 2,000,000 variable speed units in the field.

In addition to the standard off-the-shelf products, you can select from a wide variety of options to customize controls for your specific application. For further information and application assistance, contact your local Dart sales representative, stocking distributor, or Dart Controls, Inc.

Dart Controls, Inc.

Manufacturer of high quality DC and AC motor speed controls and accessories since 1963.

5000 W. 106th Street
Zionsville, Indiana 46077
Phone: (317) 873-5211
Fax: (317) 873-1105

www.dartcontrols.com
ISO9001 REGISTERED
MADE IN USA