



TeleChief[®] Series TM2000 / TM4000 / TM6000

Owners Manual

Failure to return the Warranty Registration document (enclosed) to Control Chief within 30 days of purchase will void any warranty responsibilities on behalf of Control Chief Corporation

Control Chief Corporation
200 Williams Street Bradford, PA 16701
814-362-6811 * 1-800-233-3016 * 814-368-4133 (fax)
www.controlchief.com



Control Chief Corporation, a world leader in wireless radio and infrared remote control products has developed and expanded upon this powerful technology. More than three decades of experience in designing, manufacturing and installing state-of-the-art remote communication systems emphasize Control Chief's mission.

Our systems are tailored to virtually any environment or application. Control Chief provides training, technical support, and comprehensive system design to maximize performance. It is our honor to uphold this reputation of innovative engineering and superior product performance.



Publication: 95-00-0-036 Rev D
Copyright © 2002, 2003, 2007 Control Chief Corporation
All Rights Reserved.

200 Williams Street, Bradford, Pennsylvania, 16701
Web Page: www.controlchief.com
Telephone: (814) 362-6811, FAX: (814) 368-4133

1.0 Radio Warranty

- 1.1 Warranty
- 1.2 Warranty Period
- 1.3 Warranty Service
- 1.4 Excluded Parts
- 1.5 Remarks

2.0 Safety

- 2.1 Safety Considerations
- 2.2 Symbols
- 2.3 Warnings

3.0 Standard Components

- 3.1 Receiver (RX)
- 3.2 Transmitter (TX)
- 3.3 Accessories per Radio Transmitter

4.0 Installation Procedure

- 4.1 General Precautions
- 4.2 Receiver Preparation
 - 4.2.1 Power Supply Selection
 - 4.2.2 Open / Closed Setup
- 4.3 Receiver Installation
 - 4.3.1 Radio Schematics
- 4.4 Remote Setting
- 4.5 Transmitter Setup

5.0 Operation

- 5.1 Standard Operation
- 5.2 Emergency Shutdown Procedure

6.0 Basic Troubleshooting and Maintenance

- 6.1 General Precautions
- 6.2 General Error Code and Resolutions
- 6.3 Change of Fuse
 - 6.3.1 DC Type
- 6.4 Change of Frequency / Crystal

7.0 Function Settings**8.0 Specifications**

- 8.1 General
- 8.2 Transmitter
- 8.3 Receiver

9.0 Receiver Mounting Diagram

1.0 Radio Warranty

- 1.1 **Warranty.** Control Chief Corporation guarantees that this equipment meets its published specifications at the time of shipment from the factory. This equipment will perform as described if installed properly. However, Control Chief cannot guarantee that operation of remote control system is absolutely error-free, or without interruption.
- 1.2 **Warranty Period.** This equipment is warranted against defects in materials and workmanship for a period of one (1 year from the date of shipment. During the warranty period, Control Chief is responsible for necessary repairs/replacement as long as the product can be proven defective.
- 1.3 **Warranty Service.** For warranty service or repair, this equipment must be returned to Control Chief Corporation. Customer is responsible for shipping charges to Control Chief. Control Chief's warranty covers only parts and factory labor. No onsite in and out charges are covered under this warranty.
- 1.4 **Excluded Parts.** This warranty does not include consumable parts such as joysticks, batteries, fuses, buttons, and relays. Also, this warranty does not cover defects caused by improper installation, improper/insufficient maintenance, unauthorized modification, improper operation, ignorance of environmental specifications, and/or improper software/interfaces.
- 1.5 **Remarks.** No other warranty is expressed or implied, except for the above mentioned. The remedies provided herein are the buyers' sole and exclusive remedies. Control Chief shall not be liable for any direct/indirect, special, incidental, or consequential damage. Consult Control Chief's general warranty for further information.

2.0 Safety

2.1 Safety Considerations

1. The safety guidelines in this manual are not intended to replace any rules or regulations or any applicable local, state, or federal governing laws. The following information is intended to be used in conjunction with other rules or regulations already in existence. It is important to read all safety information before operating any wireless radio remote control system.
2. Only properly trained persons designated by management should be permitted to operate wireless radio controlled equipment. Wireless radio controlled equipment should not be operated by any person who cannot read or understand signs, notices and operating instructions that pertain to the equipment.
3. Wireless radio controlled equipment should not be operated by any person with insufficient eyesight or hearing or by any person who may be suffering from a disorder or illness or is taking any medication that may impair judgment or the ability to operate equipment.
4. Do not use this device during electrical storms or under conditions of electrical interference, due to the potential for equipment communication issues. Ensure transmitter batteries are in good condition and power for receiver is correct. Installation and maintenance should be done only while the controlled equipment main power and receiver's power are off and locked out to prevent electrical shock.
5. Any person operating wireless radio controlled equipment should possess the following knowledge and/or skills:
 - Knowledge of hazards peculiar to equipment operation
 - Knowledge of safety rules for radio controlled equipment
 - Knowledge of standard methods of hand and/or non-verbal signaling
 - Knowledge of the radio transmitter
 - Limit switch test procedure
 - Proper clearance of all moving parts on the radio controlled equipment
 - Proper storage space for radio control transmitter when not in use
 - Transferring radio control transmitter to another person
 - Reporting unsafe or unusual operating conditions
 - Remote controlled equipment capacity and limitations
 - Procedures for testing controlled equipment

6. Aisles between equipment, stock, etc., should be free of obstructions so the radio control operator can move freely. These aisles should meet local regulations.
7. Radio controlled operators should always position themselves for the best view of the equipment they are controlling. The equipment should never be operated blindly. The operator should always remain at a safe distance, without losing line of sight with the equipment.
8. Transmitter switches should never be mechanically blocked ON or OFF for any equipment motion. When not in use turn the transmitter off (STOP).
9. After daily operation, shut off main power in crane/machine and the power to the receiver. A secure storage space should be designated for the transmitter unit especially when not in use. This precaution is intended to prevent unauthorized use of the equipment.
10. The equipment operator should keep all body parts away from any moving parts and should never be positioned under a lifted load. Do not make a lift or move a load if anyone is in a location where they could be struck by the crane/equipment or the load.
11. If the equipment fails to respond properly, the crane/equipment operator should stop operation, turn the transmitter off (STOP). The operator should immediately report the condition to his/her supervisor.
12. The crane/equipment operator should turn off the transmitter and take it with him/her when and if boarding the equipment.
13. Remote control operation should NEVER be used for "people moving" applications. Never use remote operation if there are people aboard the controlled equipment. The remote control operator should NEVER "ride" on the controlled equipment.

WARNING

ALWAYS PLACE CRANE/EQUIPMENT IN MANUAL OPERATION AND SECURE THE WIRELESS REMOTE CONTROL TRANSMITTER PRIOR TO PERFORMING ANY MAINTENANCE.

14. The equipment has been tested for correct operation before delivery from the factory. However, it must not be used in critical or hazardous operation where incorrect operation may cause personal or equipment damage. If the equipment fails to respond or behaves improperly, the equipment operator should NOT operate the equipment AND should notify his/her supervisor immediately. When serious conditions are noticed (conditions that make the crane/equipment unsafe to operate), the equipment should be shut down immediately and the supervisor notified.

CAUTION

THE RECEIVER UNIT OR RELAYS ARE NOT RATED AS EXPLOSION PROOF. THE RECEIVER UNIT MUST NOT BE INSTALLED OR OPERATED IN EXPLOSIVE ENVIRONMENTS UNLESS APPROPRIATE SECONDARY ENCLOSURE MEASURES ARE TAKEN.

WARNING

THE UNIT MUST BE WIRED TO THE CORRECT VOLTAGE; FAILURE TO DO SO MAY DAMAGE THE SYSTEM.

NOTE

IN AN EMERGENCY, PUSH "STOP" TO STOP RADIO REMOTE CONTROLLED EQUIPMENT.

2.2 Symbols

1. This product and related documentation must be reviewed for familiarization with safety markings and instructions before operation. This product requires strict adherence to instructions in order to ensure operational safety. The following symbols may be found on the remote control or throughout the remote control documentation. Their purpose is to alert you to potentially dangerous situations.

**Refer To Manual**

When the product is marked with this symbol refer to the instruction manual for additional information.

**High Voltage**

Indicates presence of hazardous voltage. Unsafe practice could result in severe personal injury.

**Protective Earth Ground**

Indicates protective earth terminal.

**Warning**

Denotes hazard. Included text will give proper instructions. Failure to follow instructions could result in severe personal injury and/or property damage.

**Caution**

Denotes hazard. Included text will give proper instructions. Failure to follow instructions could result in minor personal injury and/or property damage.

2.3 Warnings



1. Read this manual carefully before operating and installing this product.
2. Due to the complex nature of equipment, it is necessary to read the entire manual before installation.
3. Only authorized personnel should service this equipment. Unauthorized work on this unit will void the warranty.
4. This manual is for reference only; please call your distributor or Control Chief if further assistance is required.



5. The equipment has been tested for correct operation before delivery from the factory. However, it must not be used in critical or hazardous operation where incorrect operation may cause personal or equipment damage.
6. After daily operation, please shut off main power in crane/machine and the power to the receiver.
7. Transmitter should be placed in a safe place when not in use to avoid accidental pressing of buttons.
8. The crane/machine should be equipped with mainline contactor, limit switches, and other required safety devices as dictated by CMAA, OSHA, or all other applicable governing regulations.



9. The GND (ground) of receiver must be connected to ground of crane/machine, or electrical shock can occur.

10. Do not use this device during electrical storms or under conditions of electrical interference.
11. Ensure transmitter batteries are in good condition and power for receiver is correct.



12. Installation and maintenance should be done only while the crane/machine's main power and receiver's power are off and locked out to prevent electrical shock.
13. Contents of the manual may be amended by the manufacturer without notice.

3.0 Standard Components

A standard TeleChief® wireless pendant system consists of a single (1) receiver and one (1) or two (2) handheld transmitters. AC and DC input voltage receivers are available. See paragraph 4.2.1 for available variants.

Note: All replacement part orders require the System Serial Number and the Channel Number for proper frequency matching.

3.1 Receivers



TM2000 AC Receiver, Part Number = 701P0040
 TM2000 DC Receiver, Part Number = 701P0040-DC

TM4000 AC Receiver, Part Number = 701P0060
 TM4000 DC Receiver, Part Number = 701P0060-DC

TM6000 AC Receiver, Part Number = 701P0080 (shown)
 TM6000 DC Receiver, Part Number = 701P0080-DC

3.2 Transmitters



TM2000 Transmitter, Part Number = 701P0004



TM4000 Transmitter, Part Number = 701P0006



TM6000 Transmitter, Part Number = 701P0008

3.3 Accessories Per Radio Transmitter

1. Alkaline batteries (2 pieces)
2. Strap for transmitter (1 piece)
3. Owners manual (Part number 95-00-0-036)

4.0 Installation Procedure

4.1 General Precautions

1. Observe all safety precautions when climbing or working on the machine.
2. Turn off the main power source of crane/machines before installation to avoid electric shock. Lockout/Tagout the main power source.
3. Receiver must be installed as to not touch any part of the crane/machine or structure during the operation, except for mounting provisions.
4. The receiver must be fastened securely via shock-proof mount provided.
5. Before installation, inspect the crane/machine's safety devices and make sure everything is in proper working condition.
6. To avoid any interference, the receiver must be located away from motors, frequency drives, and power cables (Section 4.3).
7. **Coil suppressors are recommended on all contactor coils and relay coils. Control Chief recommends RC type suppressors (Control Chief part number 0700-8002).**
8. In outdoor applications make sure all case fasteners are tightened firmly. The recommended torque setting is 35-40 inch-pounds. Make sure cord grip is secure. If the receiver is mounted with the antenna facing sideways or upwards, wiring pigtail must be positioned with a drip loop. See illustration for preferred mounting.

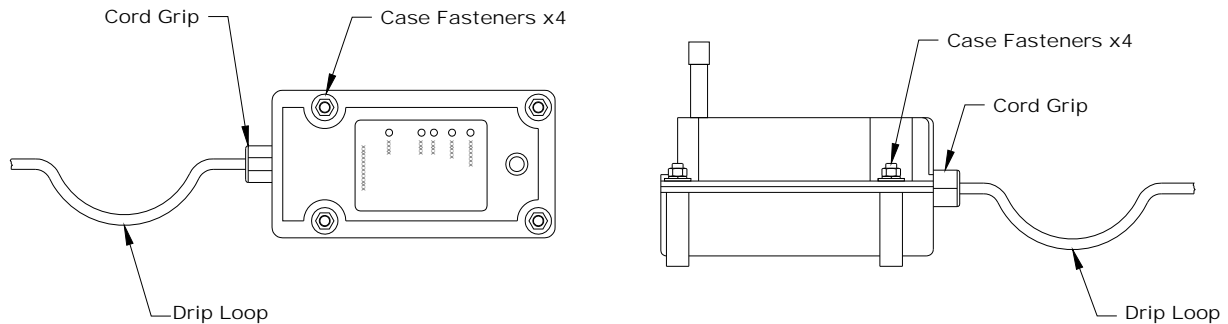

4.2 Receiver Preparation

4.2.1 Power Supply Selection

There are two types of power voltage (DC and AC) available for the TeleChief® Series:

DC Type

Input voltage: 12~24VDC. Wire + DC to Power 1 (black) and DC - to Power 2 (white).

Relay Contact: 15A-32VDC

AC Type (3 different transformers: 48/110V, 110/220V, 220/380V)

The voltage selection jumper is:

	LOW	HI
1. AC 48 / 110 V Transformer	48V	110V
2. AC 110 / 220 V Transformer	110V	220V
3. AC 220 / 380 V Transformer	220V	380V

1. Locate the Hi/Low jumper to the lower left of the transformer.
2. Place the jumper connecting the two pins to enable the correct transformer setting as shown in the chart above.

Note: The default transformer is the 48V/110V version and jumper is normally set on Hi. Please contact your distributor for other options and lead-times.

4.2.2 Normally Open / Normally Closed Setup

The TeleChief® Series provides 2 different outputs for the R0/START relay: N.O. and N.C. The N.O. is the default setting. If an N.C. output is necessary, please remove the No. 8 wire (RO/Start) from the connector and insert it into No. 10 as shown in steps 1 through 4 below:

NC Procedure:

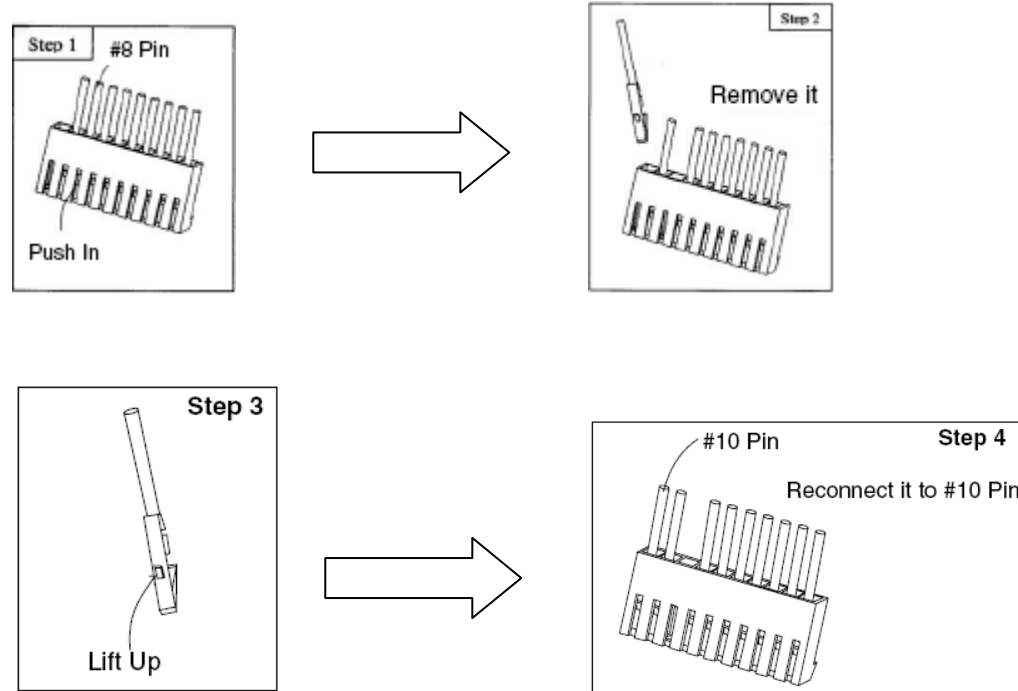

4.3 Receiver Installation

1. Turn off main power to the crane/machine.
2. Locate a proper place for the receiver.
 - a. Select a stable place free from electrical noise, vibration, excessive heat, etc.
 - b. Select a location that is visible from the operator's location.
 - c. Select a location at least 3 feet away from motors, relays, power cables, and frequency converters.
 - d. Keep away from high voltage wiring and devices.
 - e. The receiver box must be at least 1.5" (4cm) from other obstacles.
3. Drill four (4) 6 mm holes for the receiver mounting the unit with the included hardware.
4. Connect wires to the control circuit of the crane/machine according to the wiring diagram of the receiver. (Shown in Section 4.3.1)
5. Secure the cable between the receiver and the machine so that the cable sheath will not wear out due to vibration.
6. Complete Section 4.5 and test every function of the radio control making sure all motors are correct.
7. Secure the cover making sure not to pinch any wires between the case and the lid.
8. This completes the receiver installation.

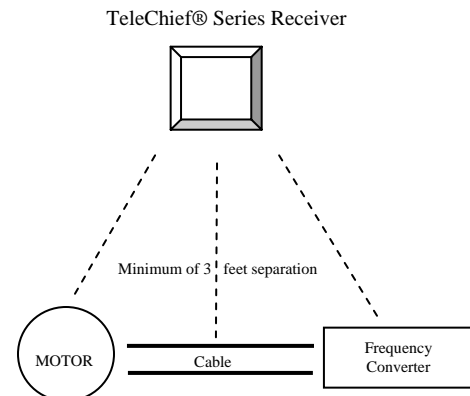

4.3.1 Radio Schematics

AC Models

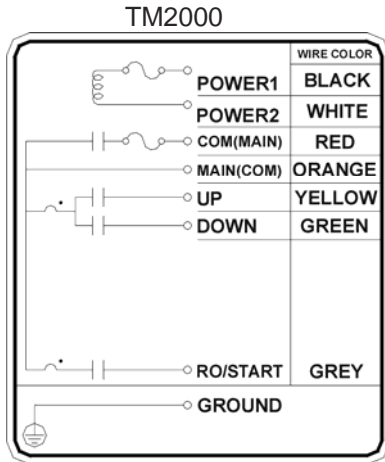

4-button wiring schematic

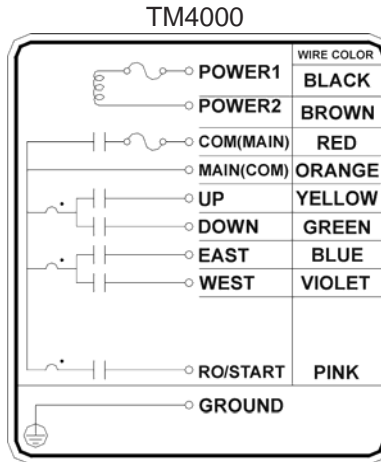

6-button wiring schematic

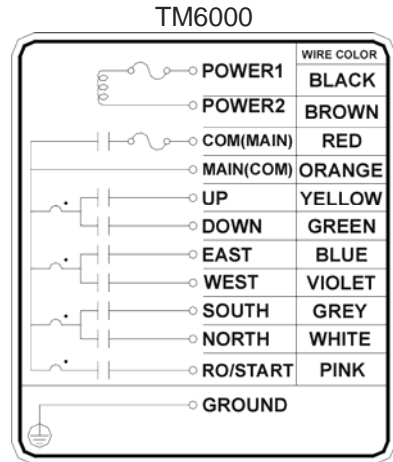

8-button wiring schematic

DC Models

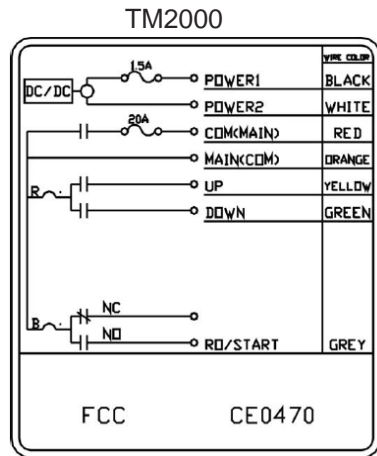

4-button wiring schematic

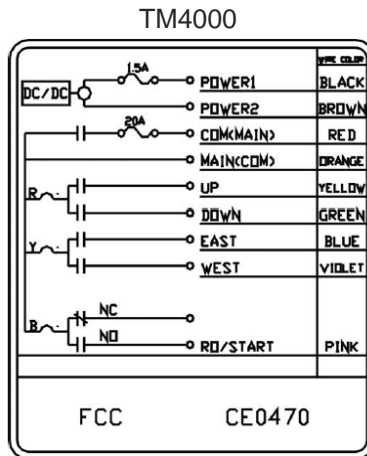

6-button wiring schematic

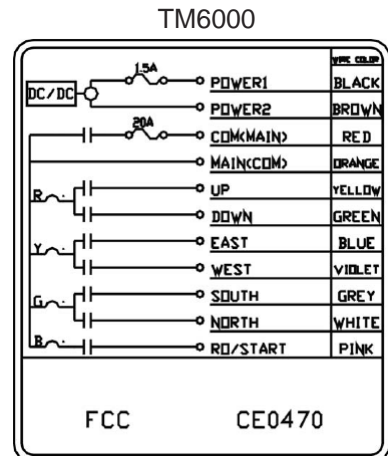

8-button wiring schematic

4.4 Remote Setting

Remote setting allows you to pair the new transmitter and receiver if either of them becomes damaged. In order for the radios to work the transmitter and receiver must have the same ID codes and frequency. Using remote setting will set both the transmitter and receiver to have the same ID codes.

1. Please ensure the following conditions are met before attempting the remote setting procedure.
 - a. Both the transmitter and receiver are of the SAME model and frequency.
 - b. To place the transmitter as close as possible to the receiver to avoid any interference.
 - c. Turn off the receiver power and turn it on again.
 - d. Complete the "remote setting" within 4 minutes after turning on the receiver. The receiver will NOT accept the remote setting signal after 4 minutes has elapsed.
2. Remote Setting instructions
 - a. Press and hold the transmitter STOP pushbutton.
 - b. Press the DOWN pushbutton and hold it.
 - c. Press the UP pushbutton 4 times and release "STOP & DOWN" pushbuttons when the red light flashes.
 - d. Start the system per General Operation (Section 5.0).



ATTENTION:

- * In case the remote setting procedure fails, repeat the instructions above within 4 minutes.
- * The remote setting procedure will update the ID code only. It will not change function settings.
- * All same model systems within the operating distance on the same frequency will be paired with the transmitter's ID code.

4.5 Transmitter Setup

Two (2) AA size alkaline batteries are required for the transmitter. The LED will flash GREEN when the battery power is sufficient. The LED will flash RED when the battery power is low.

Note 1: The operating distance will decrease when the batteries are low.

Note 2: Replace with new batteries when battery power is low.

Note 3: Re-chargeable batteries are NOT recommended, use only alkaline batteries.

5.0 Operation

5.1 Standard Operation

1. Turn-on the main power switch of the equipment.
2. Install two (2) AA size alkaline batteries in the transmitter.
3. Press the Start/RO pushbutton to turn on the main relay inside the receiver.
4. Operate normally according to the function settings.
5. Please perform the following procedure when done operating
 - a. Press STOP pushbutton
 - b. Place the transmitter in safe storage location
6. Turn off the main power switch to the equipment

5.2 Emergency Operation

In case of any emergency please:

1. Press STOP pushbutton.
2. Switch off the main power of crane/machine. If the problem persists, contact your local distributor for service.

6.0 Basic Troubleshooting and Maintenance

6.1 General Precautions

Daily inspection is important and will ensure safe operation. Inspection should include testing the emergency stop and other safety devices and functions. If there is any doubt, operation must be stopped immediately and problems be corrected before operation is resumed.

6.2 General LED Error Codes and Resolutions

- | | |
|--|--------------------------------------|
| 1. Transmitter LED flashes RED quickly (every 0.2 seconds) when any button is pressed: | One of the pushbuttons is jammed. |
| 2. Transmitter LED flashes RED slowly (every 0.5 seconds): | The transmitter memory is defective. |
| 3. Transmitter LED is steady RED when any button is pressed: | The transmitter batteries are low. |
| 4. Receiver Error LED flashes slowly (every 0.5 seconds): | The receiver memory is defective. |

Note: The receiver error LED is located on the inside of the receiver. Observe the appropriate precautions when opening the unit.

IF A PROBLEM IS FOUND, PLEASE CONTACT THE DISTRIBUTOR FOR REPAIR.

6.3 Change of Fuses

Depress the fuse cover and turn counter-clockwise with a flat screwdriver to open up the fuse cover. Remove the old fuse and insert a new fuse into the cover. Place fuse cover along with the fuse into the fuse holder base. Depress the fuse cover and turn clockwise with flat screwdriver.

Legend: F= Fuse

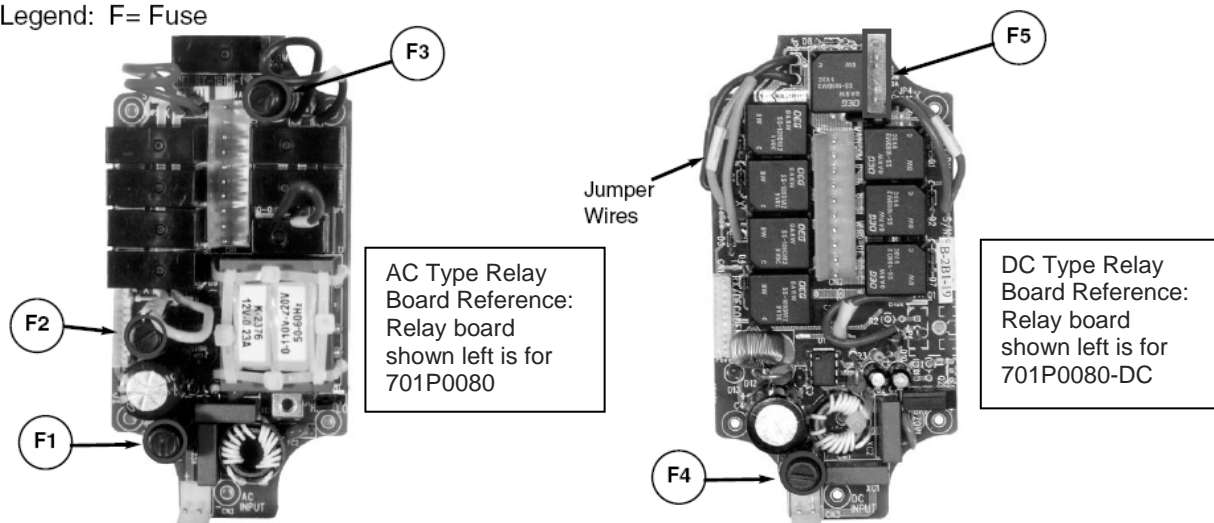

6.3.1 Change of fuse, DC Type

Unplug the yellow fuse "F5" (20A) and replace with a new one

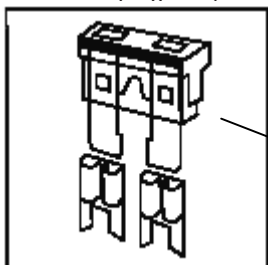

Ref Fuse Number	Size	Fuse Type
F1	.5A	5 x 20 mm
F2	.5A	5 x 20 mm
F3	10A	5 x 20 mm
F4	1.5A	5 x 20 mm
F5	20A	Std Double spade

6.4 Change of Frequency/Crystal

The frequency of the TeleChief® Series can be simply changed by replacing the correspondent crystal frequency in both the transmitter and receiver. Please refer to below procedure in regards to replacing the crystal.

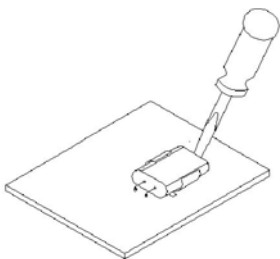

1. Gently pry up the crystal unit with a flat screwdriver

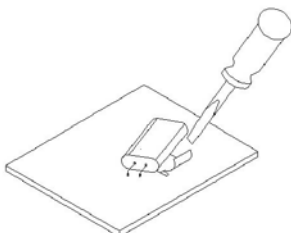

2. Remove the crystal unit from the system

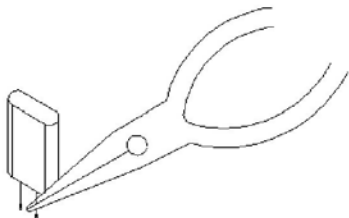

3. Use needle nose pliers to straighten both pins of the new crystal unit

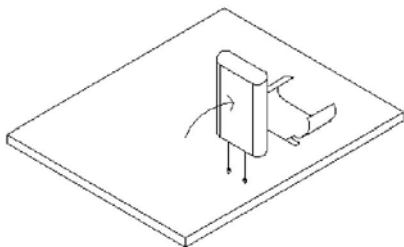

4. Insert the new crystal unit vertically into the PC board

5. Add dot of RTV to clip and press the new crystal down into the socket, bending the pins.

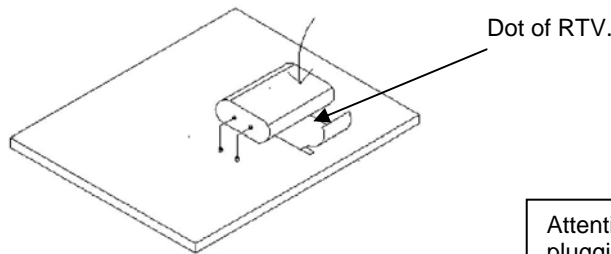

Attention: The frequency is different when plugging the same crystal into the transmitter or receiver.
For example:

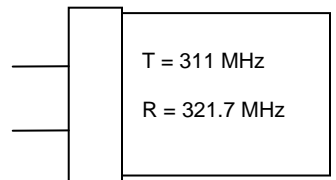

- ▶ Frequency for transmitting is 311 MHz
- ▶ Frequency for receiving is 321.7 MHz

Contact your distributor for different matched crystal sets.

7.0 Function Settings

The TeleChief® Series offers the following function settings in the transmitter:

- Momentary
- ON-OFF
- Maintained
- Interlocked

By default they are set in an interlocked momentary mode. TeleChief® Series radios can be custom programmed at the factory based on requirements and specific applications. Please contact your distributor for more information.

8.0 Specifications

8.1 General

<ol style="list-style-type: none"> 1. Enclosure: IP65 2. Structure: Glass Fiber/Nylon 3. Operating Temperature: -45° ~ +80° C -50° ~ +175° F 4. Relay: 10A/250VAC (AC Power); 15A/12VDC (DC Power) 	<ol style="list-style-type: none"> 5. ID Code: 32 bit (Greater than 4 Billion Unique Codes) 6. Hamming distance > 4 bits 7. Static > 15KV 8. Remote ID Code Setting 9. Operating range: up to 328 ft (100 meters)
--	--

8.2 Transmitter

<ol style="list-style-type: none"> 1. L x W x H: 4.72 x 2.17 x 1.00 in. (120 x 55 x 25 mm) 2. Weight: 5.47 oz. (155g) (w/ batteries) 3. Uses 2 AA alkaline batteries 4. Low power indicator (LED flash red) 5. Pushbutton jammed detector 	<ol style="list-style-type: none"> 6. Shock resistance 7. Output power < 4mW 8. Normal power consumption : 10 mA 9. Sleep mode consumption : < 1 µA 10. Modulation: FM
--	---

8.3 Receiver

<ol style="list-style-type: none"> 1. L x W x H: 6.34 x 2.91 x 2.05 (161 x 74 x 52 mm) 2. Weight: 2.43 lbs. (1.1 kg) (without cable) 3. AC type: 48/110, 110/220, 220/380VAC DC type: 12V~24VDC 	<ol style="list-style-type: none"> 4. Sensitivity: approx. -105dBm 5. Shock resistant design 6. Four independent common lines (U/D, E/W, S/N,RO)
--	---

9.0 Receiver Mounting Diagram

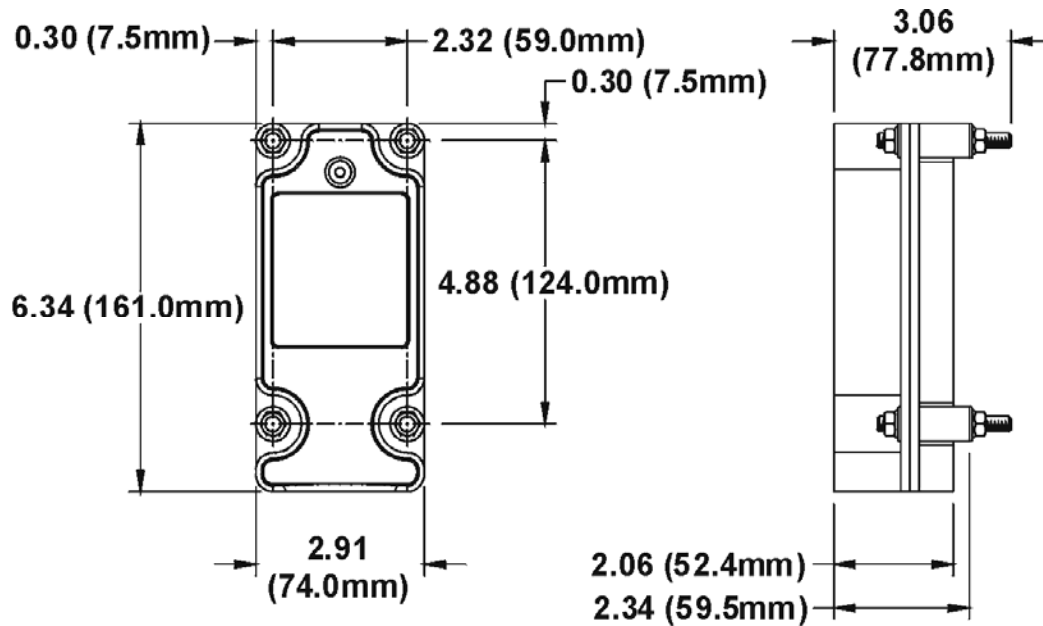

Installation Questions?

Technical assistance is available from Control Chief.

Please call us at 814-362-6811 or email the service department at prodserv@controlchief.com



Control Chief Corporation
200 Williams Street
PO Box 141
Bradford, PA 16701
814-362-6811 * 1-800-233-3016 * 814-368-4133 (fax)
www.controlchief.com